

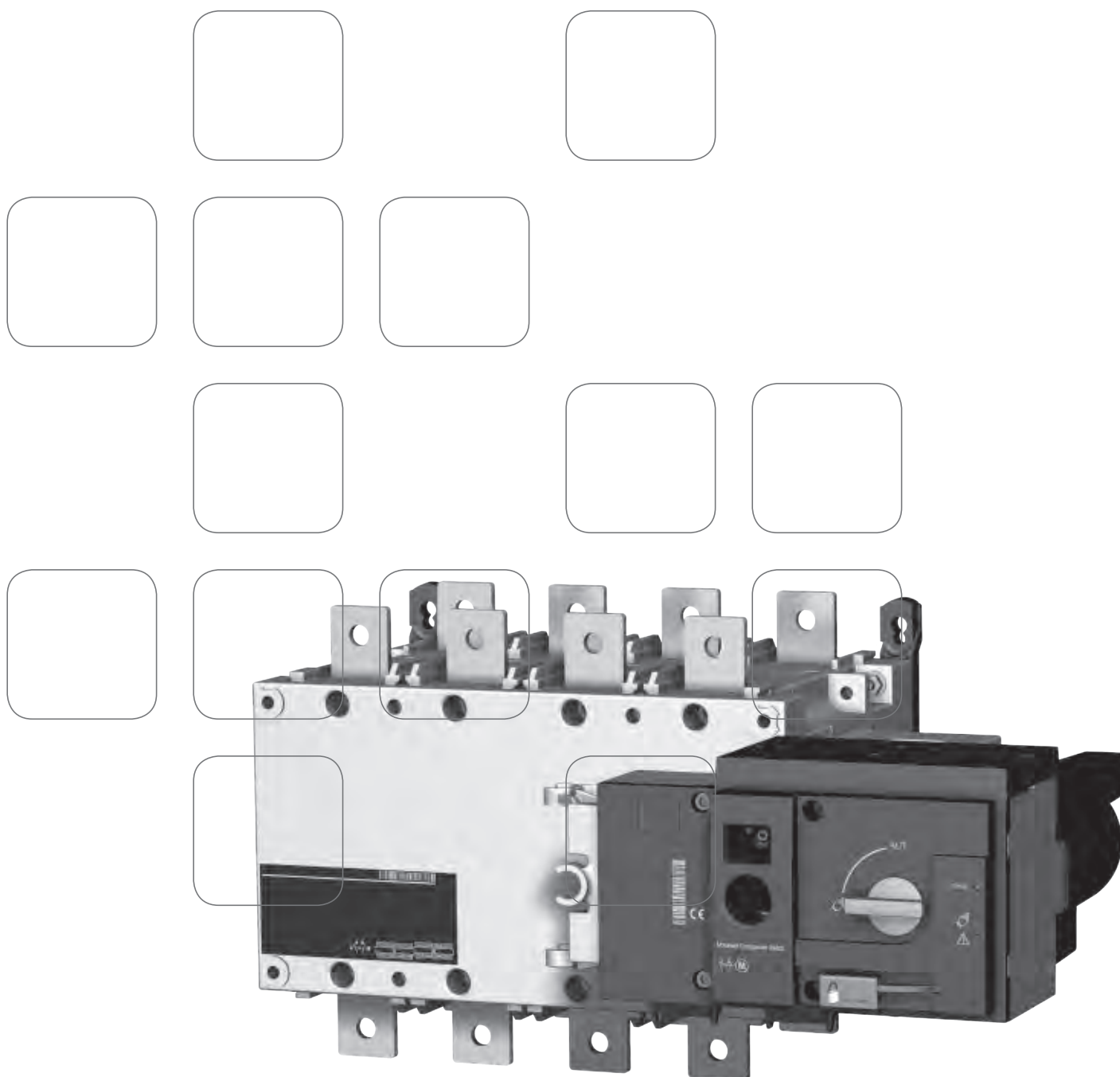

# HIB4xxM

Remote Transfer Switching Equipment







<b>General overview of the product</b> .....	2
<b>Environmental</b> .....	3
<b>Installation</b> .....	4
Dimensions from 125 A to 630 A.....	4
Dimensions from 800 A to 1600 A .....	5
Mounting orientation .....	6
Assembly of customer mounted accessories .....	6
<b>Connections</b> .....	10
Power circuits .....	10
Power supply Terminal and Control/command terminal .....	11
<b>Operating modes</b> .....	13
Manual operation .....	14
Electrical operation .....	15
<b>Trouble shooting guide</b> .....	18

## General overview of the product

- ① Power Section: Changeover switch assembly with inherent mechanical interlock.
- ② Front: Switch number 1 terminals (3 or 4 pole).
- ③ Back: Switch number 2 terminals (3 or 4 pole).
- ④ Switch position indication window :  
- I (On) - O (Off) - II (On).
- ⑤ Top cover.
- ⑥ Back-plate mounting fixing lugs.
- ⑦ Auxiliary power supply: 230 VAC (208 - 277 VAC  $\pm 20\%$   $\rightarrow$  166 - 332 Vac).
- ⑧ Motorized Control Unit.
- ⑨ Motor housing.
- ⑩ Green LED Indication: Power (if control voltage input of the product is within specified range).
- ⑪ Auto/Manual mode selector switch.
- ⑫ Emergency manual operation "Direct Handle".
- ⑬ Emergency manual operation shaft location (Accessible only in manual mode).
- ⑭ Red LED Indication: Product Unavailable/Manual Mode/Fault Condition.
- ⑮ Padlocking facility (Up to 3 padlocks of dia. 4 - 8 mm).
- ⑯ Output contacts x 4 (Position indication I - O - II and product availability outputs).
- ⑰ Handle fixing clip.
- ⑱ Input contacts x 5: Position order I - O - II, Remote control enable, Override controls and force to Off position
- ⑲ Sliders for Terminal Shields
- ⑳ Fixing holes for terminal Shields

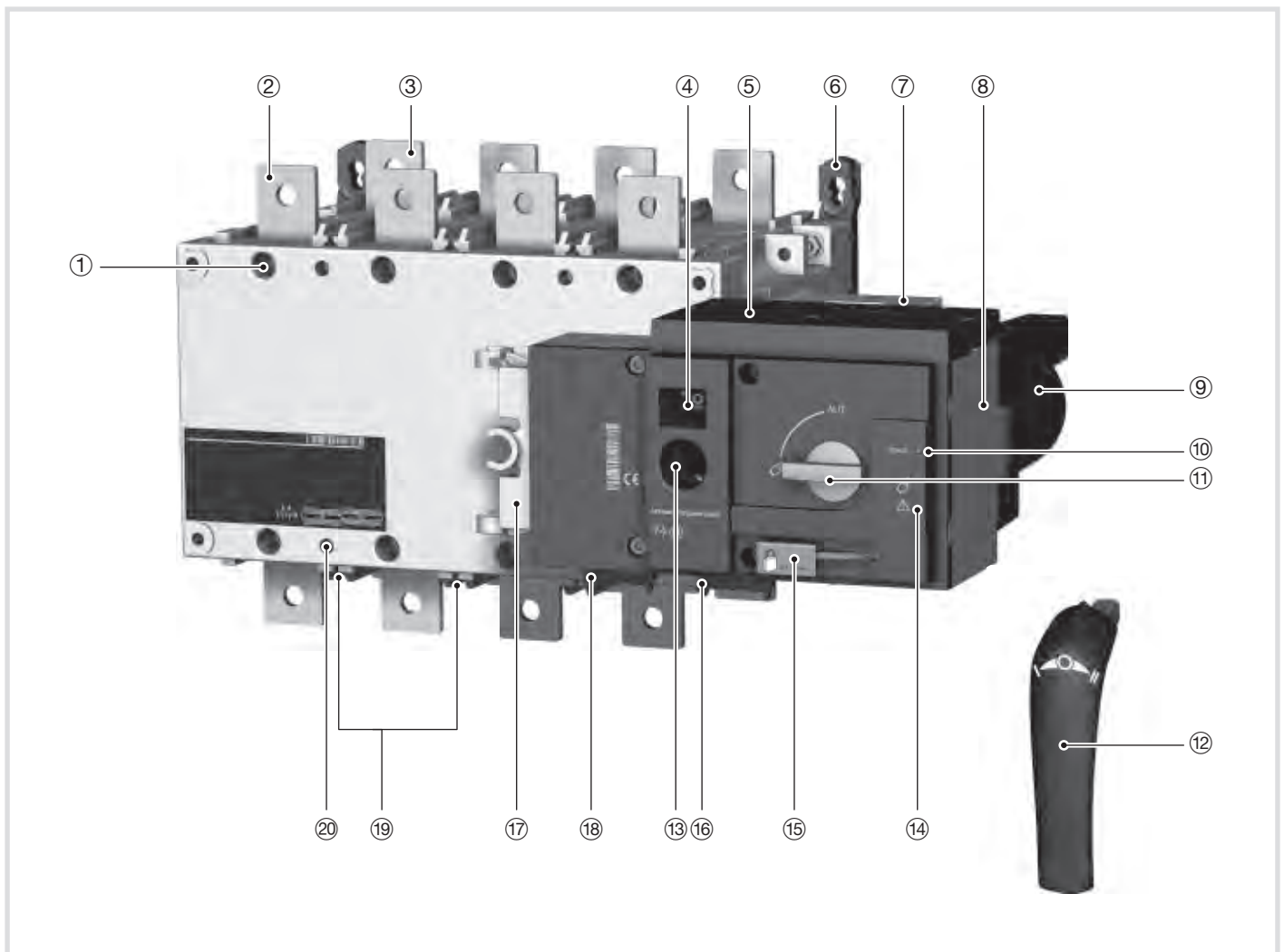



**IP Rating** IP2X against direct contact for the motorization control unit.  
 IP2X against direct contact for the power section with the connections in place and when including suitable, correctly installed incoming and outgoing terminal shields.  
 IP0 for the bare power section without terminal shields in place.

**Storage conditions** -40 °C to +70 °C

**Operating conditions** From -20 to +40 °C without derating.  
 From -20 to +70 °C when applying a Kt derating correction factor.

Kt (Correction Factor)	Temperature
0,9	40 °C to +50 °C
0,8	50 °C to +60 °C
0,7	60 °C to +70 °C

**Storage duration period** Maximum storage up to a period of 12 months.  
 Recommendation: To be stored in dry, non corrosive and non saline atmospheric conditions.

**Hygrometry** 80 % to 55 °C  
 95 % to 40 °C

**Altitude** Up to 2000 m in altitude without derating.  
 For higher altitude the Ka correction factors below apply.

Ka (correction Factor)	2000 m < A ≤ 3000 m	3000 m < A ≤ 4000 m
Ue	0,95	0,8
Ie	0,85	0,85

Frame dimensions (125A to 630A)

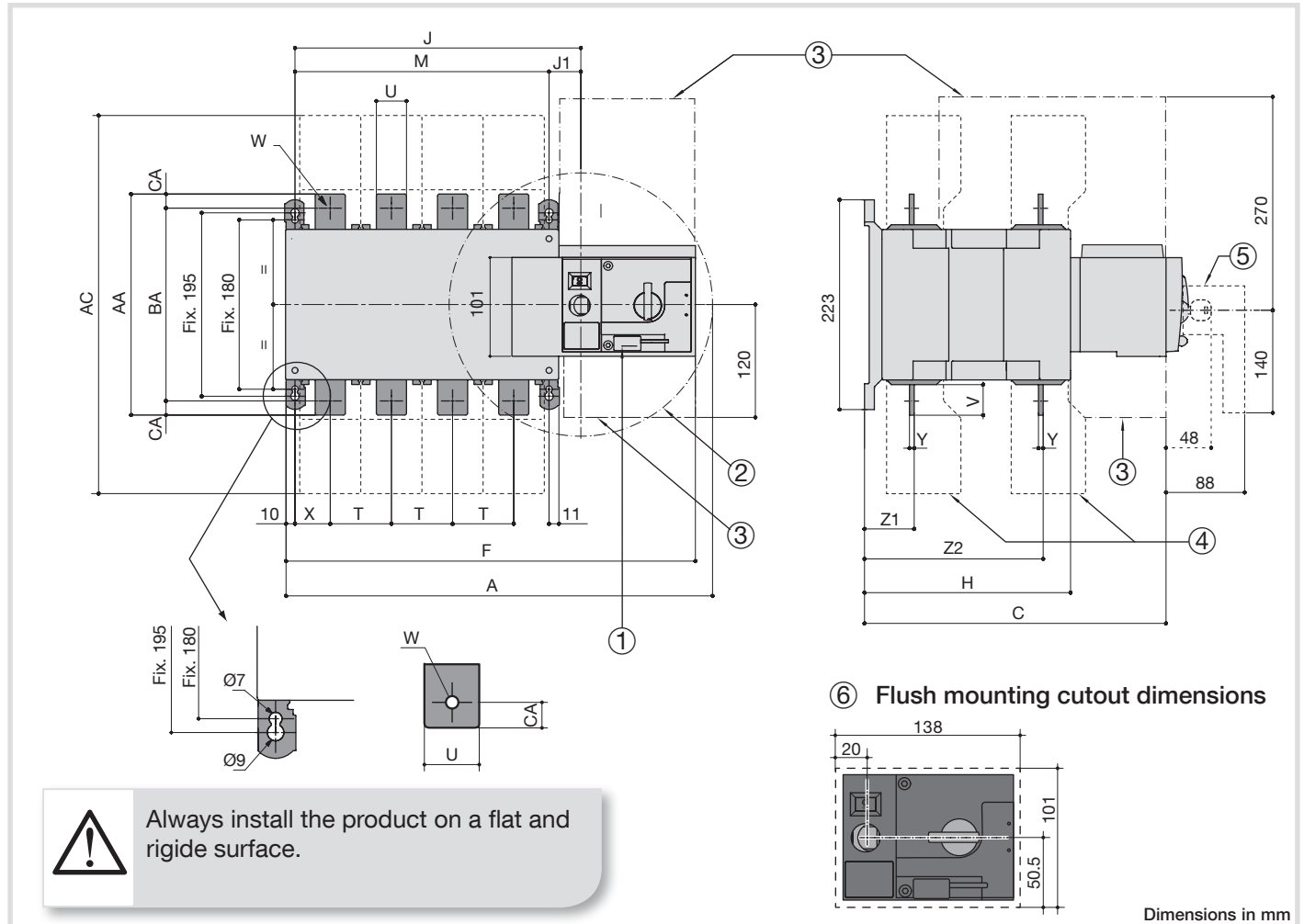

- ① Padlocking Facility: Locking bracket for up to 3 padlocks of dia. 4-8 mm.
- ② Emergency manual operation: Maximum operating radius with an operating angle of 2x90°.
- ③ Connection and disconnection area.
- ④ Terminal cover.
- ⑤ Emergency manual operation (direct handle).
- ⑥ Flush mounting cutout dimensions for front door.

To consider the space required for manual operation and wiring. (When using the emergency handle)

Rating (A)	Overall dimensions			Terminal Shrouds	body			Switch mounting	Connection										
	A	C	F		AC	H	J		J1	M	T	U	V	W	X	Y	Z1	Z2	AA
125	334	244	317	233	151	184	34	150	36	20	25	9	22	3,5	38	134	135	115	10
160	334	244	317	233	151	184	34	150	36	20	25	9	22	3,5	38	134	135	115	10
200	334	244	317	233	151	184	34	150	36	20	25	9	22	3,5	38	134	135	115	10
250	395	244	378	288	152	245	35	210	50	25	30	11	33	3,5	39,5	133,5	160	130	15
315	395	244	378	288	152	245	35	210	50	25	30	11	33	3,5	39,5	133,5	160	130	15
400	395	244	378	288	152	245	35	210	50	35	35	11	33	3,5	39,5	133,5	170	140	15
500	454	321	437	402	221	304	34	270	65	45	50	13	37,5	5	53	190	260	220	20
630	454	321	437	402	221	304	34	270	65	45	50	13	37,5	5	53	190	260	220	20

Dimensions in mm

## Frame dimensions (800 A to 1600A)

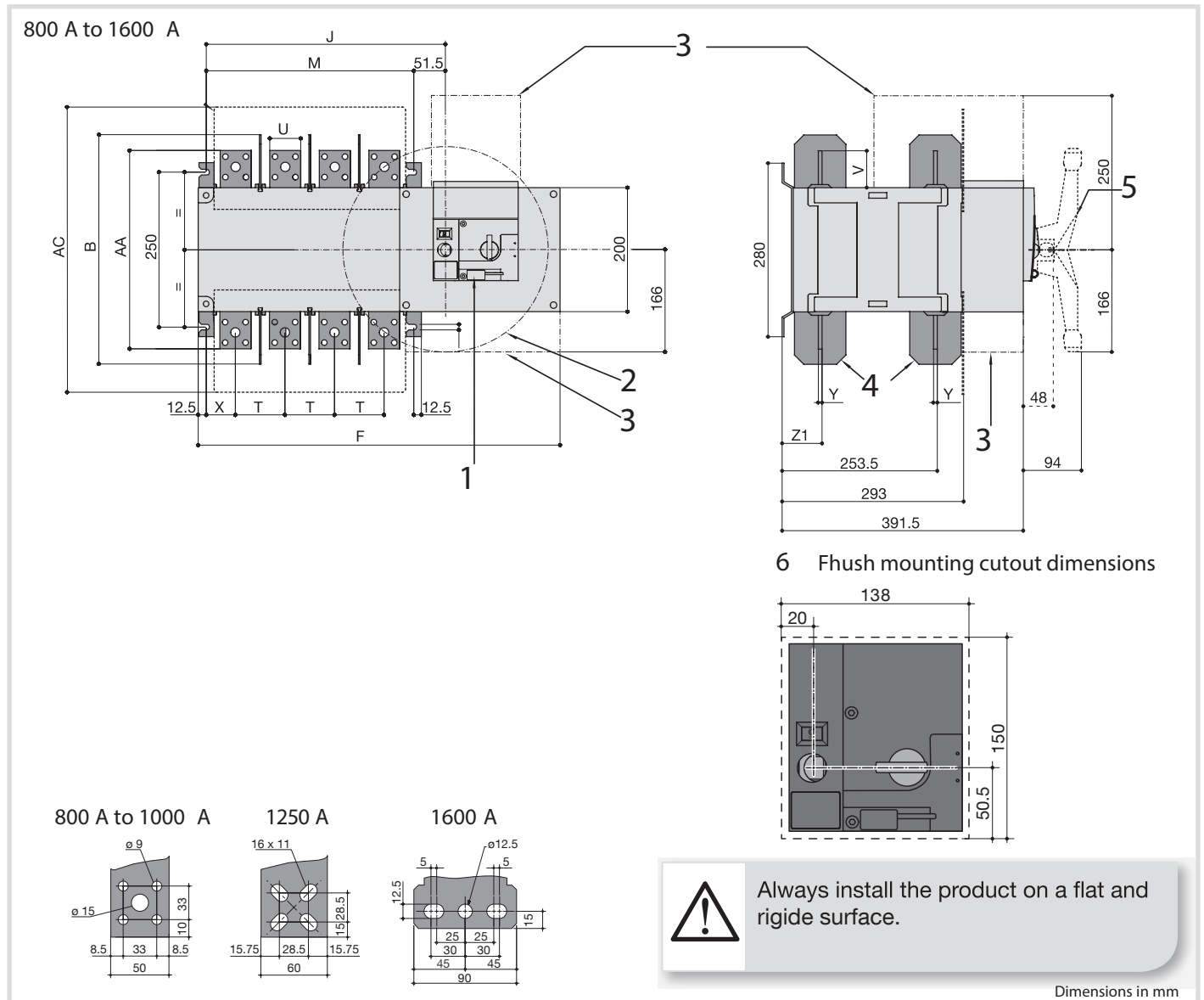

- 1 Padlocking Facility: Locking bracket for up to 3 padlocks of dia 4-8 mm.
- 2 Emergency manual operation: Maximum operating radius with an operating angle of  $2 \times 90^\circ$ .
- 3 Connection and disconnection area.
- 4 Terminal cover.
- 5 Emergency manual operation (direct handle).
- 6 Flush mounting cutout dimensions for front door.



To consider the space required for manual operation and wiring.  
(When using the emergency handle)

Rating (A)	Overall dimensions	Terminal Screens	body		Switch mounting	Connection						
			F	J		M	T	U	V	X	Y	Z1
800	370	461	584	387	335	80	50	60,5	47,5	7	66,5	321
1000	370	461	584	387	335	80	50	60,5	47,5	7	66,5	321
1250	370	461	584	387	335	80	60	65	47,5	7	66,5	330
1600	380	531	716	519	467	120	90	44	53	8	67,5	288

Dimensions in mm

## Mounting orientation

125 A to 630 A	Recommended	OK	Not Allowed	OK
800 A to 1600 A	Recommended	Not Allowed	OK	OK

## Assembly of customer mounted accessories



Never handle any customer mounted accessories while there may be the risk of voltage being or becoming present.

## Bridging bar installation

125 A to 630 A

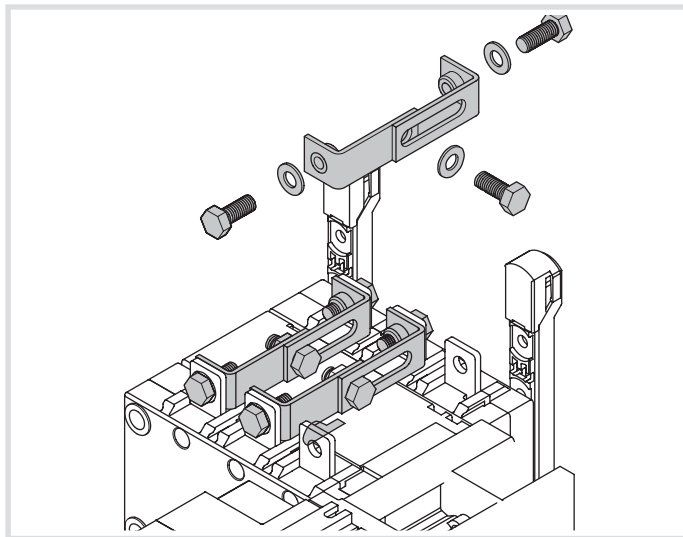

800 A to 1600 A

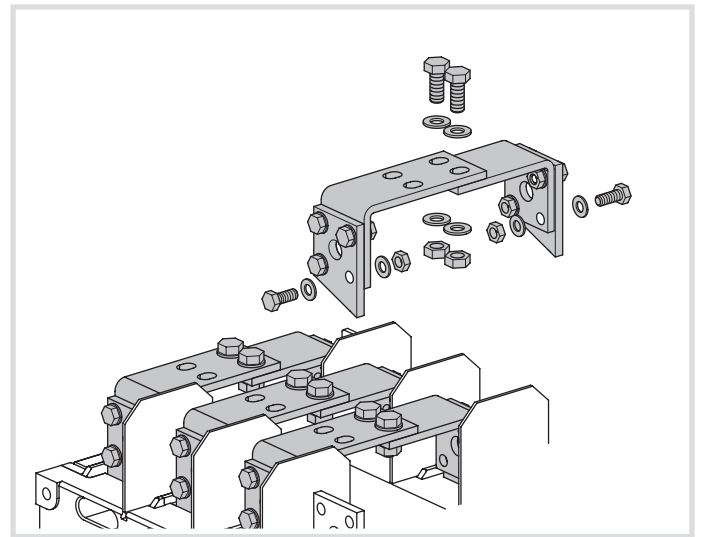

It is possible to mount the bridging bars on either side of the switch.

Recommended tightening torque:

M6: 4,5 N.m  
 M8: 8,3 N.m  
 M10: 20 N.m  
 M12: 40 N.m

Maximum tightening torque:

M6: 5,4 N.m  
 M8: 13 N.m  
 M10: 26 N.m  
 M12: 45 N.m

# Installation

## Terminal shrouds available from 125 A to 630 A



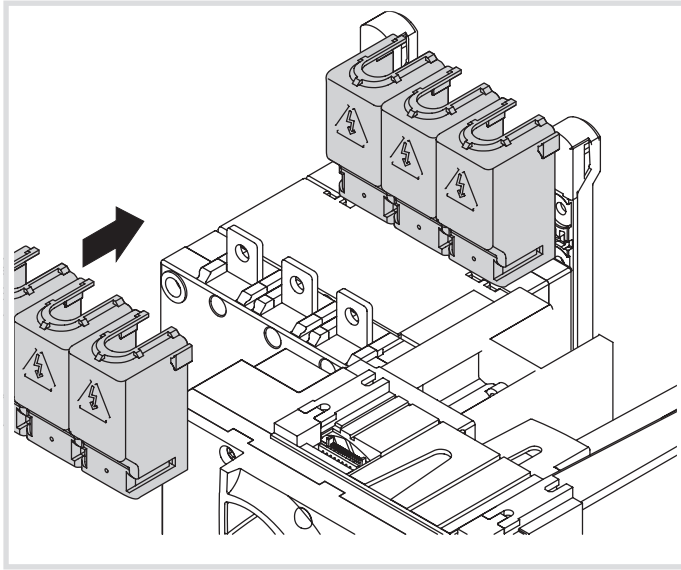

- Upstream, downstream, front or rear mounting.
- When fitted with bridging bars only the front terminal shrouds are to be installed.

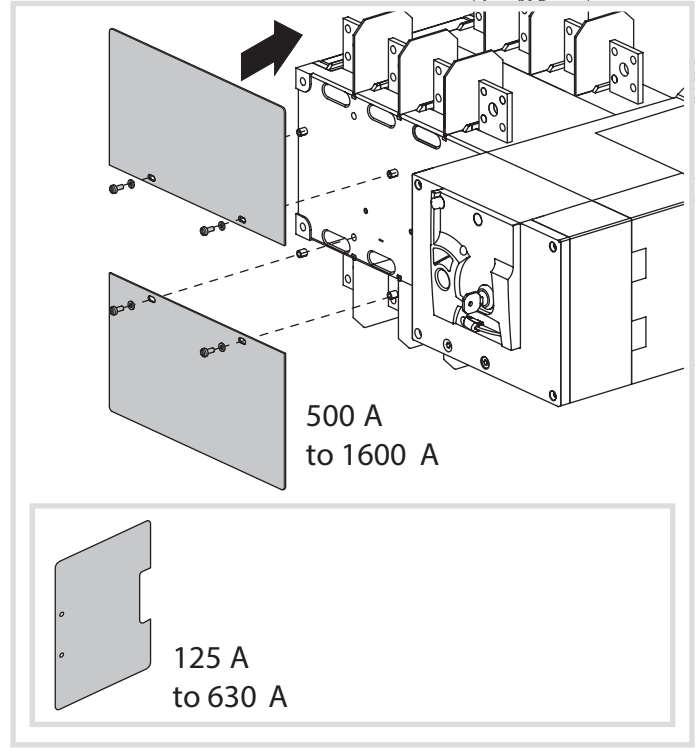

## Terminal screens available from 125 A to 1600 A

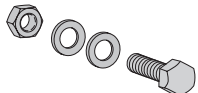

# Installation

			
		 Washer MOY. M M12 - NFE 25 511	 H M12
V01	H M12-35 6,8-x6	x 12	x 6
V02	H M12-55 6,8-x3	x 6	x 3
V03	H M12-55 6,8-x5	x 10	x 5
V04	A H M12-35 6,8-x3	x 3	-
	B H M12-45 6,8-x3	x 3	-
V05	H M12-65 6,8-x3	x 6	x 3
V06	H M12-65 6,8-x5	x 10	x 5
V07	H M12-55 6,8-x3	x 6	x 3
V08	H M12-55 6,8-x5	x 10	x 5
V09	H M12-55 6,8-x10	x 20	x 10
V10	H M12-65 6,8-x3	x 6	x 3
V11	H M12-65 6,8-x5	x 10	x 5
V12	H M12-65 6,8-x10	x 20	x 10



Data for Bolts, Nuts and Washers for Busbar connections.



Conditions of use of these products may lead to a derating .

# Connections

## Power circuits

### Cable or bar connections

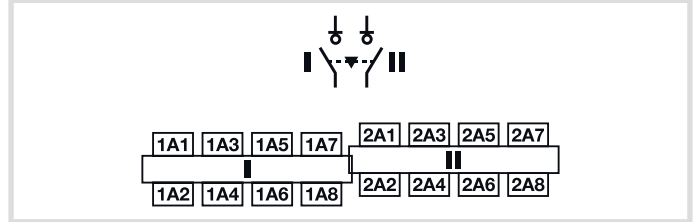
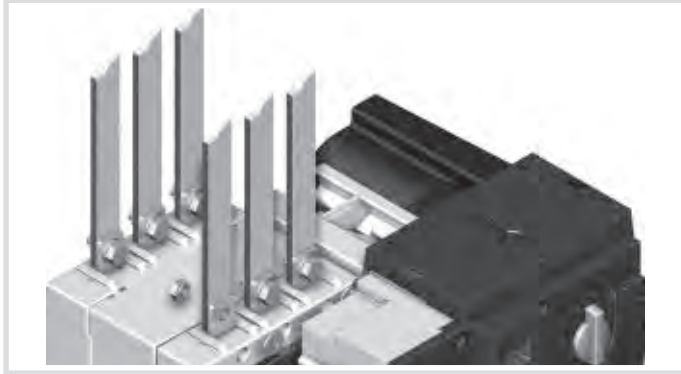

Recommended tightening torque:  
 M6: 4,5 N.m (max. 5,4 N.m)  
 M8: 8,3 N.m (max. 13 N.m)  
 M10: 20 N.m (max. 26 N.m)  
 M12: 40 N.m (max. 45 N.m)

## Power connection terminals

125 A to 630 A

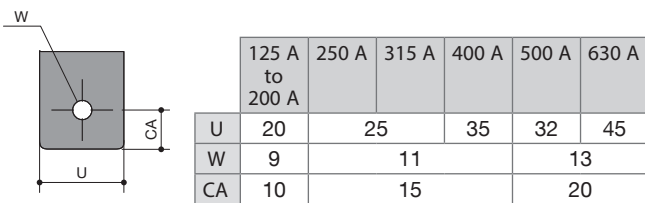

800 A to 1000 A

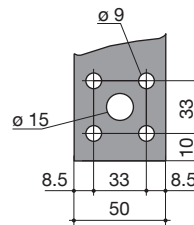

1250 A

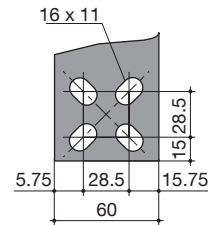

1600 A

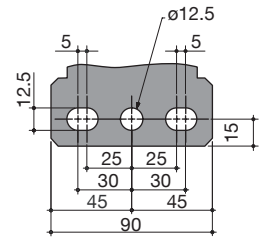

Dimensions in mm

## Power connection cross-section

	125 A	160 A	200 A	250 A	315 A	400 A	500 A	630 A	800 A	1000 A	1250 A	1600 A
Minimum cables section Cu (mm <sup>2</sup> ), lth	35	35	50	95	120	185	2x95	2x120	2x185	-		
Minimum bars section Cu (mm <sup>2</sup> ), lth	-						2x30x5	2x40x5	2x50x5	2x60x5	2x60x7	2x60x5
Minimum cables section Cu (mm <sup>2</sup> ), lth	50	95	120	150	240	2x185	2x300	2x300	4x185	4x185	6x185	
Maximum bars width Cu (mm)	25		32			50		63		100		

## Typical wiring

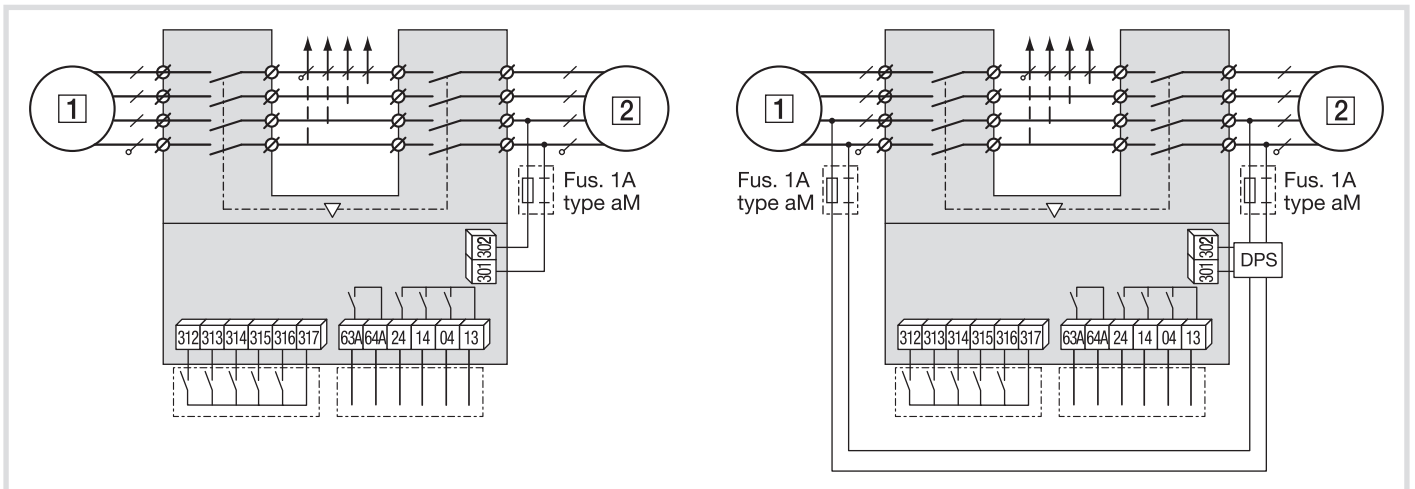

## Power supply terminal and control / command terminals

Remove the top cover to access and connect the terminal - Replace the cover before putting in service.

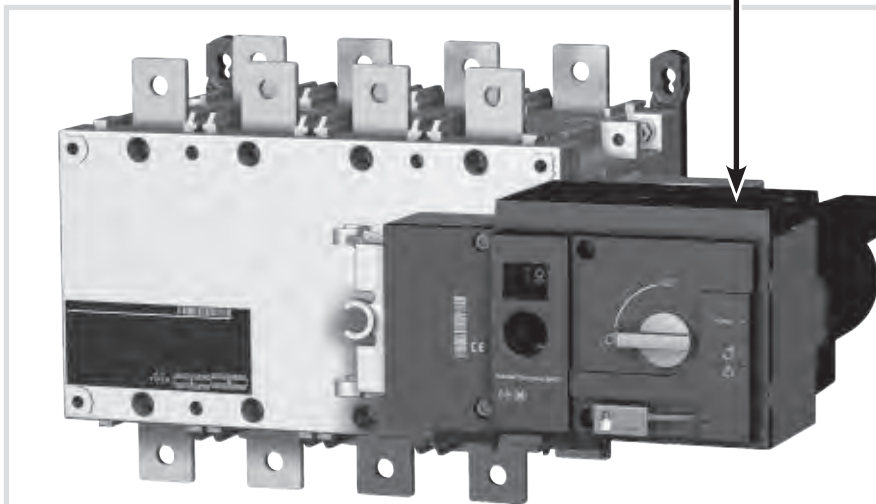
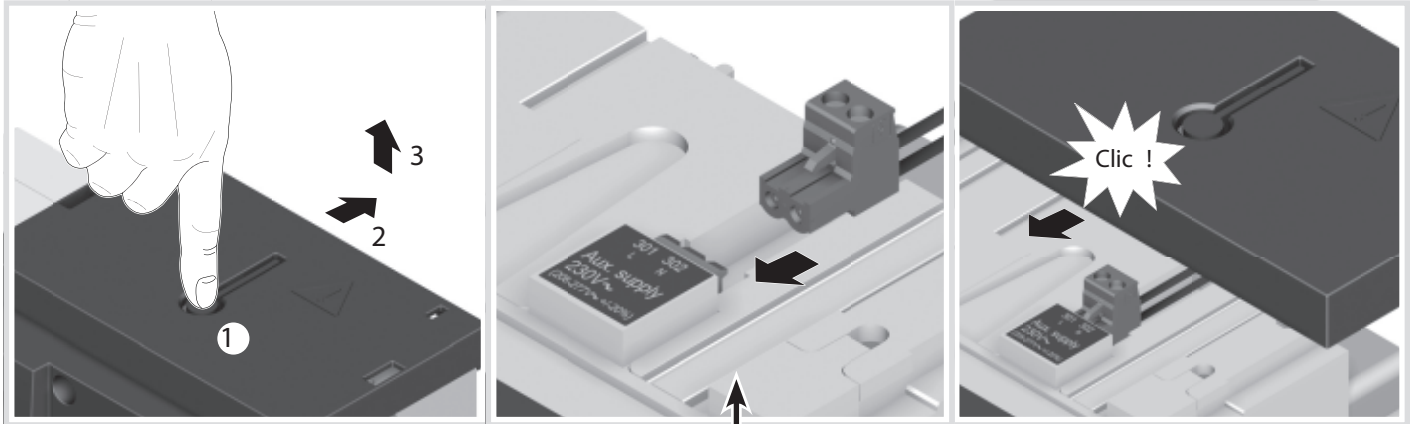



 Verify that the auxiliary power supply feeds terminals 301 and 302 are within the limits of 208 VAC ⇒ 277 VAC ±20 % (166 - 332 VAC).

301 L	302 N	Power supply L:	301
		Power supply N:	302
Aux Supply 230V~ (208-277V~ +/-20%)			

 All pressure on the connector pins is to be avoided during wiring of the auxiliary cables.

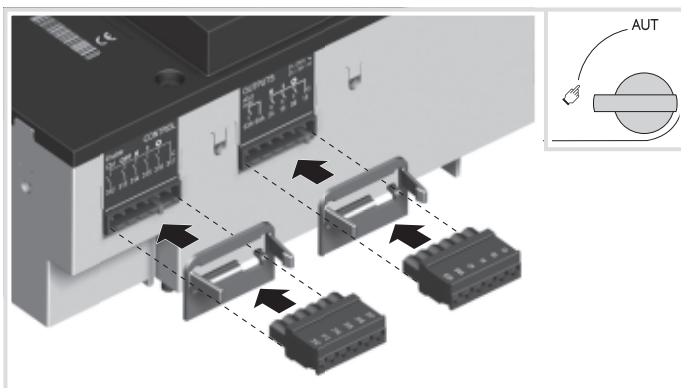
Ensure that the product is in manual mode



 Do not handle any control or power cables connected to the product when voltage may be present.

CONTROL			
Enable	Ctrl OFF II I ○	Control enable:	312
		Override to OFF :	313
		Sw to Pos II I/P :	314
		Sw to Pos I I/P :	315
		Sw to Pos O I/P :	316
		Common:	317

Use cables with 1,5 to 2,5 mm<sup>2</sup> section.  
Screw M3 - Tightening torque: mini: 0,5 Nm - maxi: 0,6 Nm.

OUTPUTS			
AVAIL.	II I ○	Prod Avail Common:	63 A
		Prod Avail O/P :	64 A
		Pos II Aux Contact:	24
		Pos I Aux Contact:	14
		Pos O Aux Contact:	04
		Common:	13



# Connections













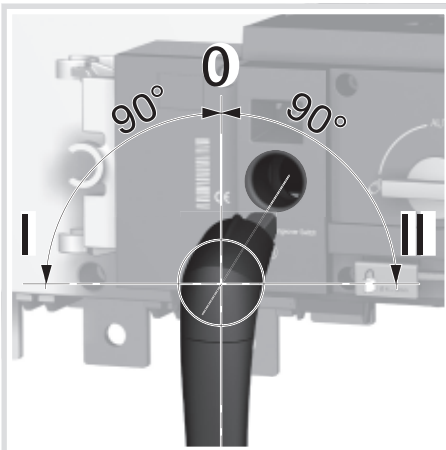

Denomination	Terminal	Description	Characteristics	Recommended Cable Section
Signalisation Outputs	13	Common I - O - II for Aux Contacts.	Dry Contacts 2A AC1/250V	1,5 mm <sup>2</sup>
	04	Aux Contact Position O - Normally Open Contact.		
	14	Aux Contact position I: Normally Open Contact.		
	24	Aux Contact position II: Normally Open Contact.		
	63 A	Product Available : Normally Open Contact. Closed when the product is in Auto mode and motorisation is operational. (No Fault powered and ready to changeover)		
	64 A			
Power supply Input	301	Power supply -L	208 -277 VAC ±20 % : 50/60Hz	1,5 mm <sup>2</sup>
	302	Power supply -N		
Control Inputs	312	Remote Control Mode Enable when closed with 317.	 <p>Do not connect terminals 312 to 317 to any power supply. These order inputs are powered through terminal 317 and external dry contacts ONLY</p> <p>Max cable length 100 m</p>	1,5 mm <sup>2</sup>
	313	Position O order if closed with 317 (Priority order input forcing the product to remote control mode and O position).		
	314	Position II order if closed with 317.		
	315	Position I order if closed with 317.		
	316	Position O order if closed with 317.		
	317	Common control terminal for 312 - 316 ATS (Specific Voltage Supply)		

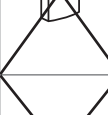
# Operating modes

The product includes 3 safe and distinct operating modes through a selector switch located on the front of the product.

The modes of operation are as follows:

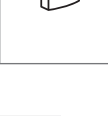
- Auto Mode: Remotely operated transfer switching,
- Manual Mode: Local emergency manual operation,
- Locked Mode: Secure locked pa locking facility.

<p>AUT mode</p>		<p>AUT</p>  	<p>AUTO Mode</p> <ul style="list-style-type: none"> <li>• Activates the remote control inputs and the controller automation.</li> <li>• Inhibits the padlocking facility.</li> <li>• Inhibits the insertion of the manual operation handle when in AUT Mode.</li> </ul> <p>AUTO Mode position is inhibited when padlocked or when the handle for manual operation is inserted into the product.</p>
<p>mode</p> 		<p>AUT</p>  	<p>MANUAL Mode (Not Padlocked)</p> <ul style="list-style-type: none"> <li>• Inhibits the control inputs.</li> <li>• Allows to insert the handle for emergency manual operation.</li> <li>• Allows padlocking in O Position. (With the handle for manual operation removed).</li> </ul> <p>Turning the selector switch to  from AUT and back to AUT resets a fault state.</p>
<p>mode</p>  		<p>AUT</p>  	<p>MANUAL Mode ( Padlocked)</p> <ul style="list-style-type: none"> <li>• Inhibits the control inputs.</li> <li>• Inhibits insertion of the emergency handle.</li> <li>• Allows padlocking when in O Position.</li> </ul>   POS 0



Depending on the state of the product the ATS automation may change the switch position as soon as the mode selector is switched to AUT. This is a normal operation.

## Manual operation

### Emergency manual operation

The product can be manually operated as a "Manual Transfer Switch Equipment - MTSE" whilst retaining the electrical characteristics and performance of the power switching function. This function is usually used in case of emergencies or during maintenance.

- To operate the product manually ensure that no live parts are accessible. Turn the front selector switch into the manual position 1 . Insert the handle into the emergency handle shaft location hole provided 2 .
- Turn the handle 90° clockwise or anti-clockwise (depending on the position to be reached) for each consecutive change in position. I ⇒ O ⇒ II ⇒ O ⇒ I.



Ensure to verify the product position and direction of rotation before effecting manual operation. Ensure to remove the handle from the product before changing the selector switch back to AUT position.



As standard, padlocking is only made possible in the "O position", when in manual mode and with the emergency handle not inserted

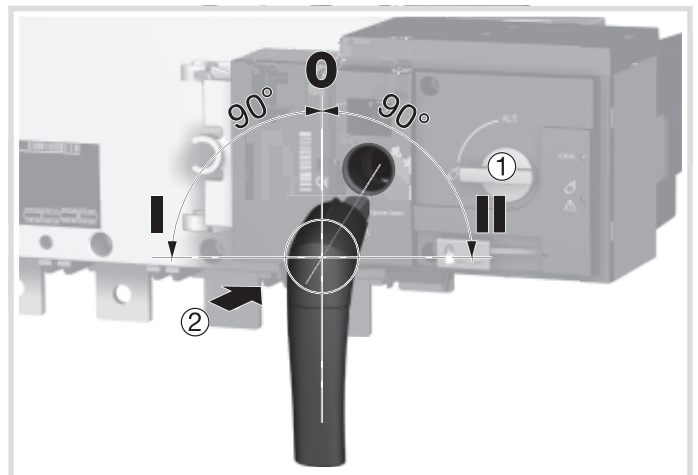

### Padlocking

The product can only be padlocked in the O position.

- To padlock the product first ensure that the mode selector switch is on Manual A then ensure that the emergency manual operation handle is not inserted into the location hole B . (Remove if inserted)
- Pull the padlocking mechanism outwards to reveal the slot for inserting up to 3x dia. 4 - 8 mm padlocks.
- Padlock the device with approved quality padlocks of minimum diameter 4 mm and maximum diameter of 8 mm. A maximum of 3x 8 mm padlocks may be padlocked onto the product to padlocking mechanism.



## Electrical operation

### Power supply

The product is to be powered between terminals 301 and 302 with a supply within the limits of:

- 208–277 VAc  $\pm 20\%$  (166–332 VAc).
- 50/60 Hz  $\pm 10\%$ .

Current Input :

- 10 mA (Standby mode).
- 15 A max (Switching mode).

Surge Protection :

- $V_{in\_sg}$ : 4/8 kV – 1,2/50  $\mu$ s.

Terminal connector :

- Minimum 1,5 mm<sup>2</sup>.
- Maximum 2,5 mm<sup>2</sup>.

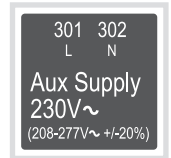

### Fixed inputs

Description

The product includes for 5 off fixed inputs through a 6 pin connector installed on the motorisation module. No additional power supply should be used on these contacts as the inputs MUST be used with the common supply taken from terminal 317.

The product Power Supply (301 -302) must be available to activate inputs 312 to 317.

Pulse duration for activation of contact inputs:  $\geq 60$  ms.

- Pin 312 : Remote Control Mode Enable when closed with 317.

This contact must be closed with 317 so as to activate all control inputs except for 313 that takes priority and is active immaterial of the state of input 312. Enabling remote control through 312 activates the remote control inputs whilst inhibiting the ATS module automation.

- Pin 313 : Position O or er if closed with 317 when in AUTO. (Force the switch to the OFF Position)

This is a "Priority Order Input" meaning that when closed with 317 it takes priority over all other electrical commands. The product will remain in O position as long as the contact 313-317 remains closed. Once the contact is open the product is ready to receive new orders. This contact order is independent of other inputs and is also enabled without 312 connected to 317. Impulse duration to activate and start switching to position O is a minimum of 60 ms. The product state will be unavailable.

- Pin 314 : Position II order if closed with 317.

This contact is active with the product in AUT mode with contact 312 -317 closed and 313-317 open. Impulse duration to activate and switch to position II is a minimum of 60 ms.

- Pin 315 : Position I order if closed with 317

This contact is active with the product in AUT mode with contact 312 -317 closed and 313-317 open. Impulse duration to activate and switch to position I is a minimum of 60 ms.

- Pin 316 : Position O order if closed with 317

This contact is active with the product in AUT mode with contact 312 -317 closed and 313-317 open. Impulse duration to activate and switch to position O is a minimum of 60 ms. For contactor logic maintain contacts on between terminal 316 and 317.

- Pin 317 : common.

Common supply for inputs 312 to 316.

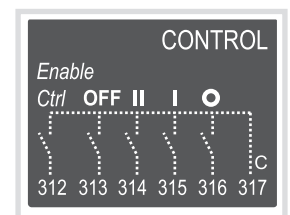

## Technical data

	Motorisation Module
Input Qty	5
Direct Current lin	0,35 to 0,5 mA
Line resistance	1 kΩ
Line length	100 m (Min. wire 1,5mm <sup>2</sup> #16AWG)
Pulse duration	60 ms
Power per Input	0,06 VA
Surge protection Vin_sg	4,8 kV (1,2/50μs surge)
ESD withstand voltage (Contact/air)	2/4 kV
Insulation (Common mode)	4,8 kVAC (Between I/P and all common parts)
Terminal connector	1,5 mm <sup>2</sup> minimum/2,5 mm <sup>2</sup> max

## Remote control logic

Remote switching operation can be driven in AUT mode by external volt free contacts as described above using input contacts 312 to 317.

Depending on the wiring configuration there are two types of logic that may be applied to the product:

- Impulse logic or
- Contactor logic.

In remote control, the product inputs give priority to orders I and II over O ; therefore contactor logic can be implemented by simply bridging terminals 316 and 317.

Nota : 312-317 closed/Force product to OFF Position, takes priority over all other orders no matter of the control logic used.

### Impulse logic:

The product is driven to a stable position (I - O - II) after receiving and impulse order.

- A switching command of at least 60 ms is necessary to initiate the switching operation.
- Orders I and II have priority over order O.

Nota : The logic diagrams exclude the transfer times.

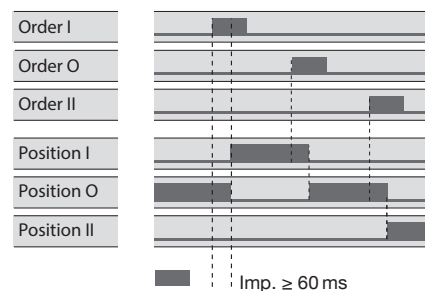

### Contactor Logic:

The product is driven to a specific position (I or II) for as long as the order is maintained.

- Order O is maintained. (Bridge 316-317).
- Orders I and II have priority over order O.
- Orders I and II have equal priority. (1<sup>st</sup> order received is held until no longer maintained.)
- If order I or II disappears, the device returns to zero position. (With the power supply available).

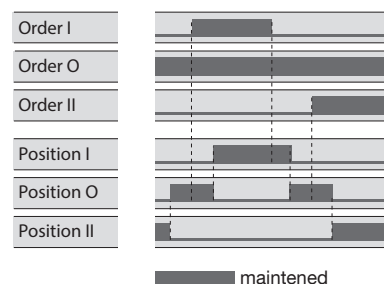

# Operating modes

## Fixed outputs - Dry contacts

The product is equipped with four fixed outputs located on the motorisation module

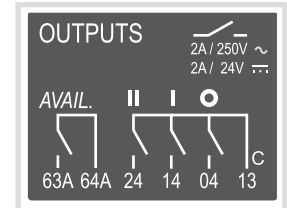

Technical characteristics	
Auxiliary Contact Quantity	4
Configuration	NO
Mechanica Endurance	100 000 cycles
Response Time	5 - 10 ms
Startup duration	200 ms
Rated Voltage/Switching Voltage	250 VAc
Rated Current	2 A
Surge protection Vin_sg	4,8 kV (1,2/50 µs surge)
ESD withstand voltage (Contact/air)	2/4 kV
Dielectric Strength contact/parts	4,8 kVAC (Reinforced Insulation)
Insulation	4,8 kVAC
Output Terminal	1,5 mm <sup>2</sup> minimum/2,5 mm <sup>2</sup> max

## Position auxiliary contact

Product is equipped with integrated position (I - O - II) auxiliary contact outputs through 3 off micro switches.

- Pins 13, 04, 14, 24 : Normally Open contacts with pin 13 as common.

## Product available output (motorisation)

- Pin 63 A - 64 A : Normally Open contact that is held closed when the motorisation is available. This contact gives constant feedback about the product's availability and its capacity to transfer from the main supply to the alternative. The feedback given is relative to the motorisation module excluding the controller that may be monitored separately. The product performs a self diagnostics test on the motorisation module at startup, when put from Manual ⇒ Auto and then every 5 minutes. This test ensures that the product is operational in terms of control inputs. Should one of the tests fail, a second test is performed to reconfirm the error state. Should the product motorisation module become unavailable, contact 63A-64A are opened, the power/ready LED's are switched off, and the fault LED is activated. The fault LED will remain active for as long as sufficient power is available and the fault condition is not reset. The fault is reset when the product is switched from AUT ⇒ Manual ⇒ AUT. Product Available/Unavailable Watchdog relay will open for any of the following reasons below: For added security, "Product Availability" is informative and does not necessarily inhibit motor operation.

Product Unavailable + Warning LED Condition:	Inhibition
Product in manual mode	Yes
Motor not detected (Autotest)	No
Control voltage out of range	Yes
Operating factor fault active (No of operations/min)	Yes
Powerfail active	Yes
Customer input autotest failed	No
Invalid product customisation	No
Abnormal switching when not in manual mode	Yes
Requested position not reached	Yes
Locked mode active when not in manual mode	Yes
External Fault ⇒ User input	No
Unexpected current flowing through the motor when idle	Yes

Sampling rate for the above is every 10 ms  
Exception: motor detection sampling rate is every 5 min

# Trouble shooting guide

It is recommended to verify the tightening torque of all connections and to operate the product in a full operating cycle (I - O - II - O - I : Auto or Manuel) at least once a year.

Note: Maintenance should be planned carefully and carried out by qualified and authorised personnel. Consideration of the critical level and application where the product is installed should form an essential and integral part of the maintenance plan. Good engineering practice is imperative whilst all necessary precautions must be taken to ensure that the intervention (whether directly or indirectly) remains safe in all aspects.

## Trouble shooting guide

The product does not operate electrically.	<ul style="list-style-type: none"> <li>• Verify the power supply on terminals 301 - 302: 208 - 277 VAC <math>\pm 20\%</math>.</li> <li>• Verify that the front selector switch is in position (AUT).</li> <li>• Verify that contacts 313 and 317 are open.</li> <li>• Verify that the power LED (Green) is On whilst the fault LED (RED) is off.</li> <li>• Verify that the product is available with contacts 63A and 64A closed.</li> </ul>
It is not possible to manually operate the switch.	<ul style="list-style-type: none"> <li>• Verify that the front selector switch position is on the Manual position.</li> <li>• Make sure that the product is not padlocked.</li> <li>• Verify the rotation direction of the handle.</li> <li>• Apply a sufficient progressive action in the direction as indicated on the handle.</li> </ul>
Electrical operation does not correspond to external order I, O, II.	<ul style="list-style-type: none"> <li>• Verify the selected control logic wiring (impulse or contactor).</li> <li>• Verify the connector connections.</li> </ul>
The fault / manuel LED is ON.	<ul style="list-style-type: none"> <li>• The FAULT/MANUAL LED is on when in manual mode (this is normal) and in AUT Mode when there is an internal fault in the product. To reset a fault condition switch the product from AUT to Manu and back to AUT. Should the fault LED remain on you will need to localize and clear the fault prior to reset.</li> <li>• The FAULT/Manual LED will also be on when contact 313 is closed with 317. (Force the product to off position). This is a normal condition.</li> <li>• Should the Fault LED remain on abnormally, contact hager.</li> </ul>
Impossible to padlock.	<ul style="list-style-type: none"> <li>• Verify that the front selector switch is in manual position.</li> <li>• Verify that the emergency handle for manual operation is not inserted into the product manual slot.</li> <li>• Verify that the product is in O position (Padlocking is only possible in O position for standard products).</li> </ul>

